



WORKSHOP SERIES

100L/MIN OIL-LESS COMPRESSOR

**Silent portable compressor ideal for general
inflating tasks.**



MODEL NO. RAS1500

Read this material before using this product.
Failure to do so can result in injury.
SAVE THIS MANUAL

For spare parts or product information please email customerservice@euroquip.co.nz



CONTENTS

INTRODUCTION.....	3
COMPONENTS AND CONTROLS.....	8
OPERATING INSTRUCTIONS.....	9
STARTING AND STOPPING YOUR COMPRESSOR..	10
USING THE INFLATOR.....	11
TOOL CONFIGURATION.....	11
RAS1500 PARTS LIST.....	14
RAS1500 PUMP PARTS LIST.....	15
WARRANTY	16

100L/MIN OIL - LESS COMPRESSOR



SUGGESTED APPLICATIONS

You may use most light duty air tools with this Compressor. Some examples of light duty tools are:

- Ball Inflator
- Toy Inflator
- Tyre Inflator
- Mini Airbrush
- Stapler
- Combo Nailer

This Compressor is NOT recommended for use with a spray gun or medium duty air tools.

INTRODUCTION

Dear Customer,

Thank you for purchasing this Compressor which has passed through our extensive quality assurance processes. Every care has been taken to ensure that it reaches you in perfect condition. However, in the unlikely event that you should experience a problem, or if you require any assistance please do not hesitate to contact us;

CUSTOMER SERVICE

Euroquip NZ: 0800 387 678

Euroquip Australia: 1800 040 947



If you have a problem, call customer service do not return this Compressor to the place of purchase.

COMPRESSOR SPECIFICATIONS:

Model:	RAS1500
VOLTAGE:	230V
FREQUENCY:	50Hz
Power:	1.5HP
Tank Size:	6L carry tank
Displacement:	190L/min 6.7CFM
FAD@7Bar:	100L/min 3.4CFM
Noise@1.5M:	61dBa
Net Weight:	16.4kg



LUBRICATION OF COMPRESSOR

This inflator is OIL FREE. Therefore there is NO oil used for lubrication.

ASSEMBLY

This Compressor **MUST** be fully assembled by you prior to use. Failure to do so will result in the warranty being VOID. Failure to fully assemble this inflator may also result in personal injury.

SAFETY

Before attempting to operate this Compressor the following basic safety precautions should be taken to reduce the risk of fire, electric shock and personal injury. It is important to read the instruction manual and to understand applications, limitations and potential hazards associated with the Compressor. This Compressor is not intended for use by persons (including children) with reduced physical, sensory or mental capabilities, or lack of experience and knowledge, unless they have been given supervision or instruction concerning the use of the appliance by a person responsible for their safety.

BEWARE OF CHILDREN AND PETS

Children and pets should be kept out of the work area. Children should not be allowed to touch or operate the Compressor, tools or extension cords. This Compressor is not designed for use by young children or infirm persons without supervision. The Compressor and tools should be kept out of reach of children, preferably stored or locked in a secure cabinet or room when not in use.

WORK AREA

Work areas and benches should be kept tidy. Cluttered benches and work areas can cause accidents. Floors should be kept clean and free from rubbish. Special care should be taken when the floor is slippery due to sawdust or wax. Always leave sufficient distance, at least 5 metres between the Compressor and the work area, especially when using tools designed for sanding or spraying liquids.

WORK ENVIRONMENT

Do not expose your Compressor to rain or use in damp or wet conditions. Keep the work area well lit.

GUARD AGAINST ELECTRIC SHOCK

Avoid body contact with earthed or grounded surfaces (e.g. pipes and refrigerators).

DO NOT FORCE COMPRESSORS

The Compressor will do a better, safer job and give you much better service if it's used at the duty cycle for which it was designed. The duty cycle will only take effect after the initial (1st) tank fill for the day. This compressors duty cycle is 50%. Duty cycle is the proportion of time during which the Compressor is operating compared with not operating. For example a 50% duty cycle could mean after 30 seconds of operation, motor pumping, the Compressor must be left for 30 seconds resting, motor not pumping. When the motor is pumping the attached air tool can not be used. Only use the attached air tool while the Compressor is not pumping. Stop using the attached tool as soon as the Compressor starts pumping.

USE THE RIGHT TOOL

Select the right tool for the job. Do not use a tool for a job for which it was not designed. Do not force a small Compressor to do the job of a heavy-duty Compressor. Do not use the Compressor for purposes not intended.



DO NOT ABUSE THE POWER CORD

Never yank or pull on the power cord to disconnect it from the mains supply socket. Never carry or pull your compressor by its power cord. Keep the power cord away from heat, oil, solvents and sharp edges. Regularly check the plug and cord and if damaged have it replaced by an authorised service facility.

EXTENSION CORDS AND REELS

This compressor MUST be plugged directly into a 240V AC wall socket.

This compressor is NOT designed to be run off an extension cord/lead. If you need extra distance do NOT use an extension cord, USE A LONGER AIR HOSE.

The use of extension cords may cause power voltage loss and will result in damage to the motor. This will NOT be covered under warranty.

SECURE THE WORK PIECE

Whenever possible secure the work piece using clamps or a vice. It is safer than using your hands or feet and leaves both hands free to control the tool.

HOT COMPONENTS

Beware many of the components will get hot during use. Never touch any of the metal pipes, pump or motor as these may burn.

MAINTAIN YOUR COMPRESSORS WITH CARE

Follow the instructions for use and changing accessories. Check the compressor power cord periodically and if damaged have it replaced by an authorised service facility. Keep handles clean, dry and free from oil and grease. Ensure that ventilation slots are kept clean and free from dust at all times. Blocked ventilation slots or air filter can cause overheating and damage to the motor and this will not be covered under warranty.

DISCONNECT COMPRESSORS

Ensure that the compressor is disconnected from the mains supply when not in use, before servicing, making adjustments or when changing any accessories.

REMOVE ADJUSTING KEYS AND WRENCHES

Form the habit of always checking to see that any adjusting keys or wrenches have been removed from the compressor or attached air tools before operating.

AVOID UNINTENTIONAL STARTING

Ensure that the switch is in the 'OFF' position before plugging the compressor into the mains power supply.

PROTECT FURNISHINGS

If using the compressor inside your house, protect furnishings and floors with a suitable dust sheet.

FIRE PRECAUTIONS

When using the compressor inside your house or workshop general fire precautions should be observed. As a precaution it is recommended that an expert is consulted on obtaining and using a suitable fire extinguisher.

CLEANING YOUR COMPRESSORS

Always disconnect your compressor from the mains power supply before you commence cleaning. Always ensure that your compressor has cooled, about one (1) hour, before cleaning and storing. When cleaning your compressor use only a damp soft cloth. NEVER use liquid or solvents of any type.

CHECK DAMAGED PARTS

Before using the compressor it should be carefully checked to determine that it will operate properly and perform its intended function.

Check for the correct alignment of moving parts ensuring that they do not bind. Check for broken or missing parts and have them replaced or repaired at an authorised service facility. Check any other condition that may affect the operation of the compressor. A guard or any other part of the compressor that is damaged should be properly repaired or replaced by an authorised service facility unless otherwise indicated in this instruction manual.

Any switch that does not operate correctly must be replaced by an authorised service facility.

DO NOT use the compressor if the 'ON / OFF' button does not turn the inflator 'ON' and 'OFF'.

PERSONAL SAFETY

Clothing

Do not wear loose clothing, jewellery or anything that could get caught in moving machinery.

Hair

Long hair should be tied back or contained in a protective covering.

Eye Protection

The use of safety goggles is highly recommended (normal glasses are not sufficient for eye protection) when using compressor. Prescription glasses do not have safety lenses.

Footwear

Where there is the risk of heavy objects or if there is a risk of slipping on wet or slippery floors, suitable non-slip safety footwear should be worn. Protect your feet from dropping accidents.

Ear Protection

The use of ear protection is highly recommended when using compressor. The continual noise may damage your ears.

Respiratory Protection

When operating any machinery that creates dust or when spray painting, an approved dust / filter mask must be worn. When machining concrete, man made fibres, especially MDF (Medium Density Fibre board), the resin used in these materials can be hazardous to your health. Use an approved face mask with replaceable filter.

Do Not Over Reach

Do not over reach. Keep a proper footing and maintain your balance at all times. Avoid using abnormal stances and awkward body positions.

Stay Alert

Watch what you are doing, use common sense, and never operate a compressor when you are tired, drinking alcohol, taking drugs or if taking medication that causes drowsiness.



WARNING

Only use Compressor when fully assembled.

Do not attempt to modify the compressor in any way; this will VOID your warranty.

The use of any attachment or accessory other than those recommended in this instruction manual could result in damage to the compressor and could cause injuries to the operator.

This electric inflator complies with Australian / New Zealand and International standards and safety requirements. Repairs should only be carried out by qualified persons using original spare parts. Failure to do so may result in considerable danger to the operator.

IMPORTANT



ELECTRICAL DATA

This compressor is fitted with a sealed electrical connection plug that is compatible with the mains power supply for Australia / New Zealand and meets the requirements of Australian Standards. This compressor must be connected to a supply voltage that is equal to that stated on the rating label. If the mains power connection plug or power cord becomes damaged it must be replaced with a complete assembly that is identical to the original, and this must be replaced by an authorised service centre. Always follow the Australian / New Zealand requirements for connection to the mains supply. If in doubt always consult a qualified electrician.

SPECIFIC SAFETY INSTRUCTIONS

Warning! Do not use the compressor in areas where there is a risk of explosion or fire from combustible materials. The sparks generated from certain tools attached to compressor can ignite combustible materials as well as flammable liquids, paint, varnish, petrol, flammable gases and dust of an explosive nature. As a precaution it is recommended that you consult an expert on a suitable fire extinguisher and its use.

- *Do not attempt to modify the compressor, guards or the supplied accessories in any way.*
- *Domestic compressor are designed for intermittent operation. Ideally a 50% duty cycle. (Meaning. 30 seconds ON motor pumping and 30 seconds OFF, motor not pumping). When the motor is pumping the attached air tool can not be used. Only use the attached air tool while the inflator is not pumping.*
- *Stop using the attached tool as soon as the compressor starts pumping.*
- *Fully assemble compressor before use.*
- *Always ensure your compressor is level and stable.*
- *Never use an extension cord with this inflator always use a longer air hose.*
- *Never connect to a generator which does not produce sufficient power, at least 1500W and has pure sine wave power output.*
- Domestic compressors are not designed for industrial / commercial applications.
- Domestic compressors are not designed for continuous running. Always follow duty cycle - 50%.
- Avoid touching the pump area as it can become very hot and may burn.
- Ensure that the compressor is disconnected from the mains supply when not in use, before servicing, making changes and when changing attachments such as air hoses / tools.
- Always use the correct type of tool for the operation to be carried out.
- Never use the compressor if any part of the unit is damaged. Always have the compressor serviced by an authorised service agent.
- Always wear safety eye, ear and respiratory protection when operating the Compressor.
- Allow the tank to completely fill before using the compressor.
- If the compressor makes an unfamiliar sound or vibrates excessively, switch the Compressor 'OFF' immediately and disconnect from the mains power supply. Investigate the possible cause or consult your authorised service facility.
- Always move the compressor using the handle and wheels.
- Always use the compressor on stable ground.
- This compressor is designed to compress normal air. Never use to compress any other type (s) of gases.
- Never direct the jet of air or other liquids / gases towards your body, other persons or animals.
- Never direct the jet of air or other liquids / gases towards this compressor.
- This compressor is not suitable for pharmaceutical, food or sanitary purposes.
- This compressor is not to be used to for filling scuba or oxygen air bottles or tanks.
- Always follow the instructions relating to the tools attached to this compressor.

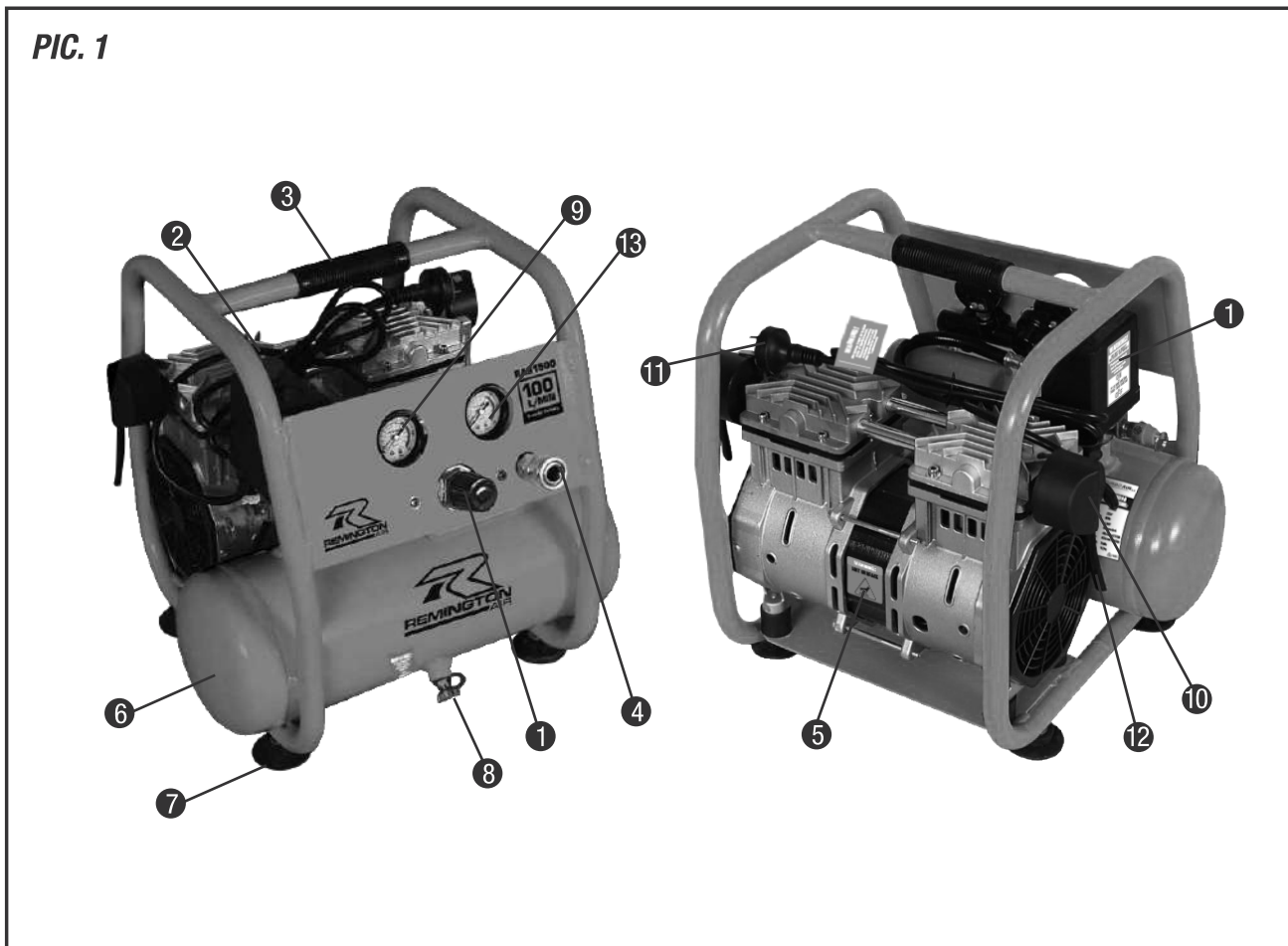

COMPONENTS AND CONTROLS

Pic. 1

1. Pressure switch
2. On / Off button - red colour
3. Handle
4. Quick Connect Outlet
5. Pump
6. Tank
7. Rubber feet
8. Tank drain tap
9. Tank pressure gauge
10. Air filter
11. 10A Plug
12. Air Filter "Quieting Tube"
13. Outlet pressure gauge

OPERATING INSTRUCTIONS

Unpacking

Carefully unpack your compressor. Dispose of all packing material in an environmentally responsible manner.

Assembly

Your compressor requires minor assembly before initial operation. Check that you have all required components required for assembly and initial use.

Rubber Stopper

To attach the rubber stopper to the bracket located on the bottom of the tank;

1. Undo the nut and remove the washer.
2. Push through the bracket and replace the washer.
3. Tighten the nut, Pic. 2

Air Filter

The supplied air filter must be used.

Failure to do so may result in irreparable damage and will void the warranty, Pic. 3

To install;

1. Carefully screw supplied air filter into the threaded hole on the top of the pump head. This only needs to be done up by hand. Do not use tools to tighten air filter.

NOTE: Do not OVER TIGHTEN as this may damage the air filter or cylinder head which will NOT be covered under warranty.

Once air filter is installed, fit the quieting tube. The quieting tube pushed into the small air filter inlet hole.

PIC. 2



PIC. 3



WARNING

Do not attempt to operate this compressor until it is fully assembled.

Damage caused due to incomplete assembly will not be covered under warranty.

Ensure the compressor is disconnected from the power supply before carrying out any assembly, maintenance or adjustments on the machine.

STARTING AND STOPPING YOUR COMPRESSOR

NOTE: Always ensure that you plug your compressor into a standard 240V AC power point. Never use an extension cord as this can lead to a voltage drop which may cause power loss and over heating. Use a longer air hose if you need to get closer to your work area.

Always start and stop the compressor using the ON/OFF button on the Pressure Switch (Pic. 1 Item 1 and 2 as well as Pic. 4). Damage caused by not using this button will not be covered by warranty.

To turn your Compressor ON;

Lift up the red ON / OFF button on top of the pressure switch

To turn your Compressor OFF;

Push down the red ON / OFF button on top of the pressure switch

RUNNING IN YOUR NEW COMPRESSOR

Your compressor does not require running in. Before use ensure you have read and understood these instructions.

Before use ensure this compressor is fully assembled as per page 10.

Positioning your new compressor

Choose a location away from your work area and near to a mains power point.

- NOTE:
1. Never use an extension lead. Always use a longer air hose
 2. Always position compressor on level ground
 3. Always position compressor away from work area so that the compressor does not get covered in dust or paint - use a longer air hose to ensure compressor is in clean air

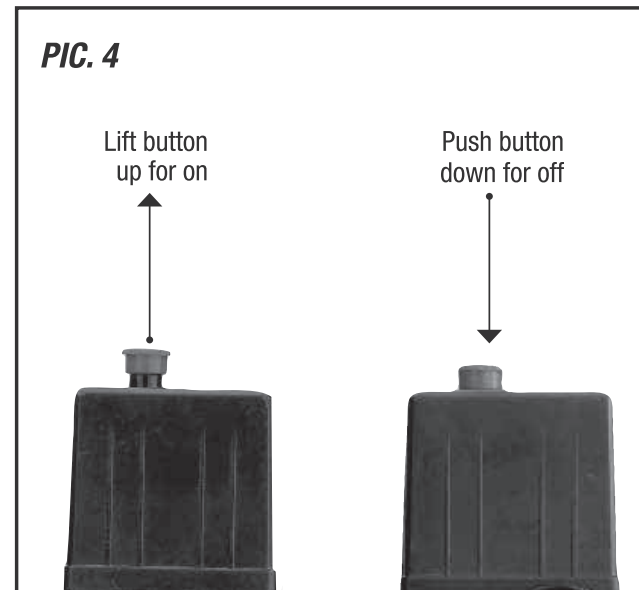

USING THE COMPRESSOR

Before starting run through this simple list;

1. Ensure the compressor is fully assembled
2. Drain tap – open and drain tank
3. Drain tap – close fully
4. Check power lead for any damage. If damaged have replaced by an authorised service centre.
5. Plug compressor into a standard 240V 10Amp AC power point and turn ON.
6. Lift the red button to turn ON, see page 11, Pic.4.
7. Allow the compressor to fill the air tank.
8. Turn the compressor OFF.
9. Turn the power point OFF and disconnect the power lead from the power point.
10. Connect your air hose and air tools.
11. Reconnect to the power lead to the power point and turn ON.
12. Turn your compressor ON.
13. Once turned on and you begin using the connected air tools the compressor will start and stop without warning. This is controlled by the pressure switch. These pressure settings are factory set and should not be changed.

Pumping starts at (minimum) 85PSI and stops at (maximum) 115PSI. Once the initial pump up stage has finished you can use the compressor. Remember to adjust the outlet air pressure to the tools recommended working pressure and open the tap fully.

TOOL CONFIGURATION

The configuration of tools and accessories can be varied to suit your particular requirements. A basic recommended set up is shown in Pic. 6 (accessories not included).

When you have finished using your compressor follow these simple steps:

1. Turn your compressor OFF, using the ON/OFF button.
2. Turn the power point OFF and disconnect the power lead.
3. Disconnect your air tools and air hose.
4. Clean your air hose and air tools.
5. Store your air hose and air tools in a secure well ventilated cabinet.
6. Slowly open the tank drain tap, see page 14. This allows excess air and moisture, water, to vent.
7. Leave the tank drain tap open. This allows any moisture to drain while the inflator is stored.

NOTE: Use of a water trap may be of benefit to ensure no water or moisture reaches your air tools.



ADJUSTING THE PRESSURE

To adjust the outlet air pressure, use the red coloured regulator knob and check the pressure on the outlet pressure gauge, Pic. 7.

If the pressure needs to be lower, turn anti clockwise.

If the pressure needs to be higher, turn clockwise.

Use the gauge to ensure you set the correct working pressure.

Note: Different air tools require different operating pressures. Always check with the tool manufacturer if unsure.

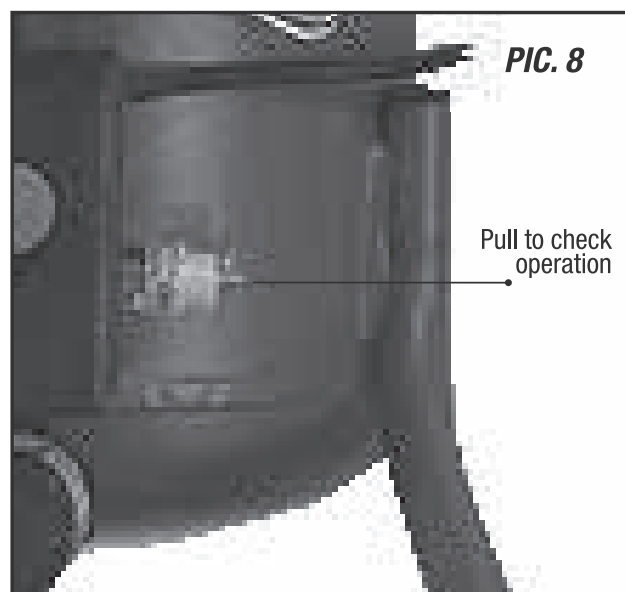
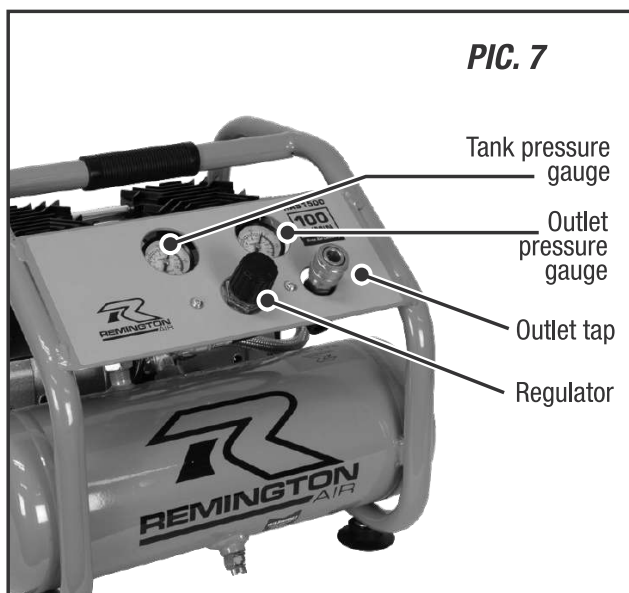

SAFETY VALVE

Pic. 8

NOTE: When checking the safety valve ALWAYS wear safety glasses.

To check the operation of the safety valve the air tank will need to be full. Gently pull the ring outwards. This should release air under pressure. Release the ring and this should stop the air out flow once the pressure has dropped.

If the safety valve does NOT work in this manner, STOP the compressor immediately and have the compressor checked / serviced by an authorised service centre.

IMPORTANT



This compressor has been supplied with no adjustable regulator and gauge.

Outlet pressure is 8 Bar (115 PSI).

If you require a lower pressure for your air tool please buy an adjustable regulator and gauge from your stockist.

AIR TAP

Pic. 9

The air tap will need to be opened to allow the air to flow to the attached air tool.

To open air tap rotate the handle so that it lines up with the fittings and hose, not supplied.

To close air tap rotate the handle so that it is at 90° to the fittings and hose, not supplied.

DRAIN TAP

Pic. 10

After use open the drain tap to drain excess air and any moisture. The excess air will also help purge the moisture. Leave the drain tap open when compressor is not in use, so any moisture can continue to drain

To open the drain tap pull the lever down to vertical.

To seal the drain tap push the lever up to horizontal.

NOTE: Remember to seal the drain tap before starting the inflator.

MAINTENANCE

Daily: Before Use

1. Seal the tank drain tap, see above, Pic. 10.
2. Check safety valve operation, see page 13, Pic. 8.

After Use

1. Open the tank drain tap, see above, Pic. 10.
2. Wipe down the compressor.
3. Store safely and securely.

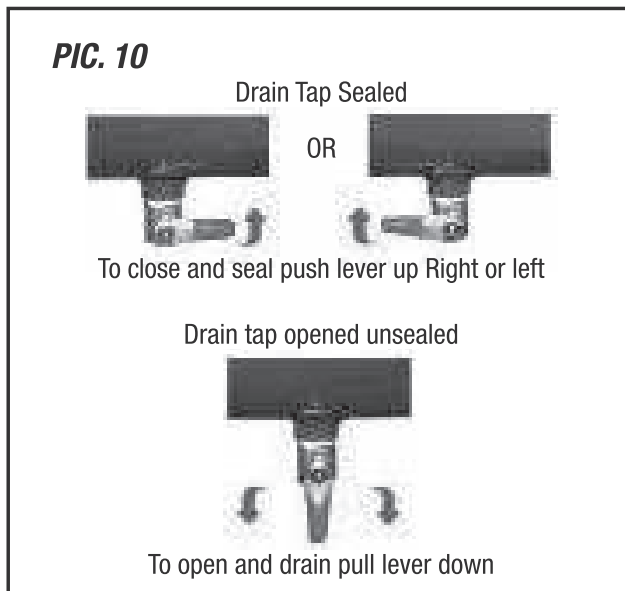
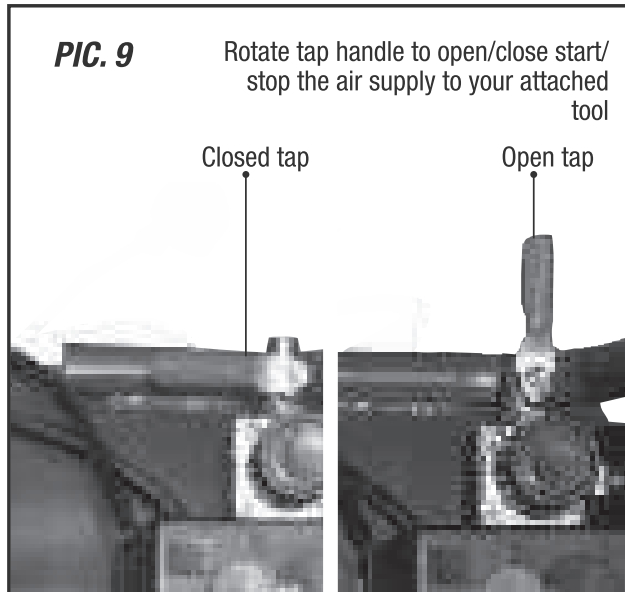

CLEANING

ENSURE the compressor is NOT running whilst cleaning. To keep the compressor clean, always wipe down after use. Wear eye protection when cleaning. Only clean the compressor with a damp soft cloth. NEVER use liquid or solvents of any type. Ensure ventilation slots are kept clean and free from dust/dirt build up.

REPAIRS

Repairs to your compressor should only be carried out by an authorised service agent.

Call Euroquip for the approved Turbo Air service agent in your area

Euroquip NZ: 0800 387 678

Euroquip Australia: 1800 040 947

? TROUBLE SHOOTING

compressor will not start

Check that you have plugged the power lead into a standard 240V 10Amp power point and turned the switch ON.

Check that you have turned the the pressure decreases to 85PSI. ON/OFF switch ON.

The air tank may be full. Use your air tool and the compressor should start when the pressure decreases to 85PSI.

compressor will not startdoes not build up pressure

Check that the tank drain tap is sealed

Check that the air fitting is not leaking. If leaking replace.

compressor will not start smells like burnt oil

Using beyond the 50% duty cycle, allow to cool for 30 minutes before reusing this compressor.

IMPORTANT



This compressor has a maximum pressure of 8 bar. Always regulate the air pressure to match your air tool. Different air tools require different operating pressures. Always check with the tool manufacturer if unsure.

RAS1500 PARTS LIST

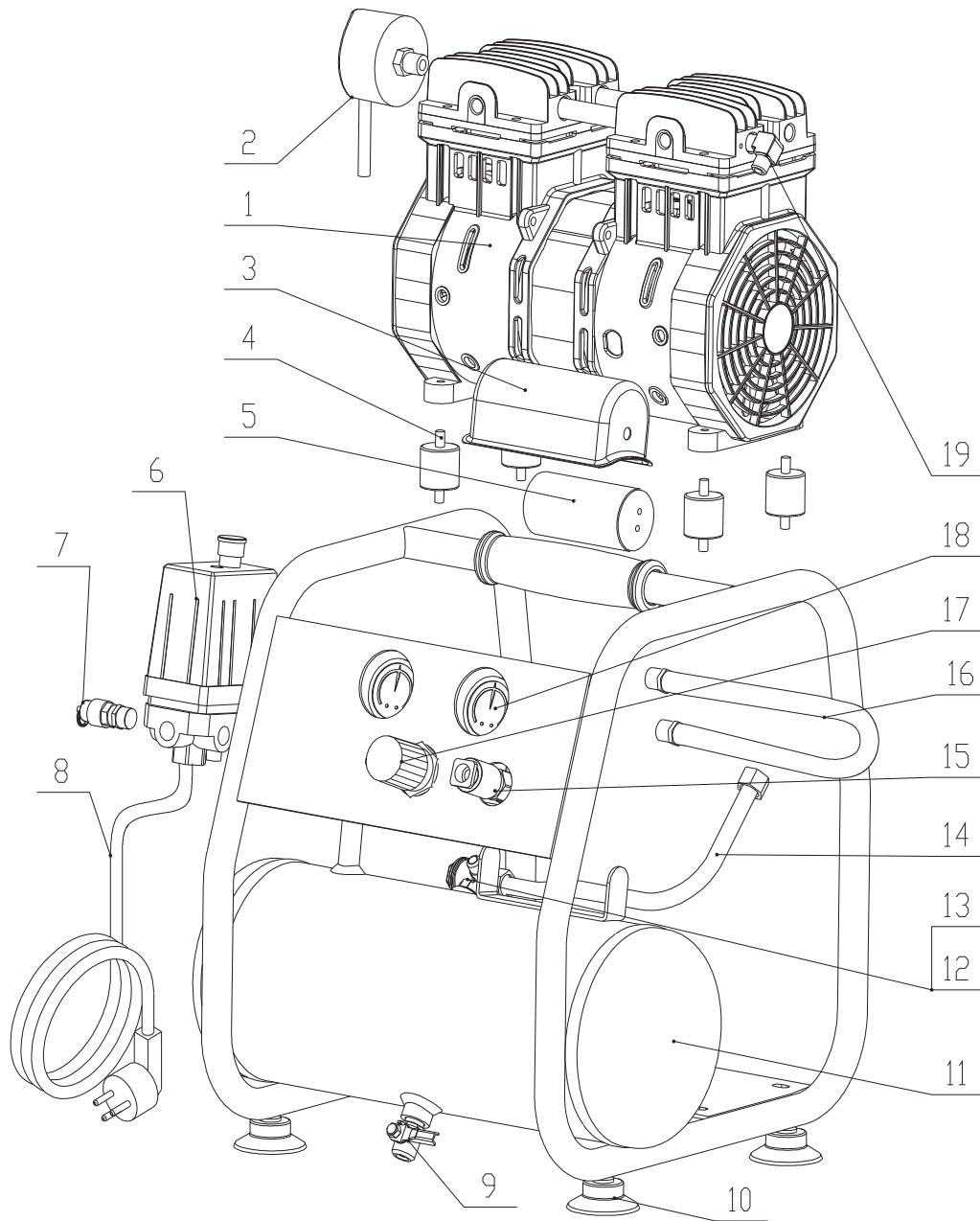

- | | | | |
|----|------------------------|----|---------------------|
| 1 | Pump Head | 11 | Tank (Coated) |
| 2 | Air Filter 1/4 | 12 | One Way Valve |
| 3 | Capacitance Cover | 13 | Realease Tube |
| 4 | Pump Rubber Screw | 14 | Discharge Tube |
| 5 | Capacitance | 15 | Outlet |
| 6 | Pressure Switch 4 -Way | 16 | Rubber Connect Tube |
| 7 | Safety Valve | 17 | Regulator |
| 8 | Power Cord | 18 | Gauge |
| 9 | Drain Valve | 18 | Elbow Connector |
| 10 | Rubber Pad | | |

RAS1500 PUMP PARTS LIST

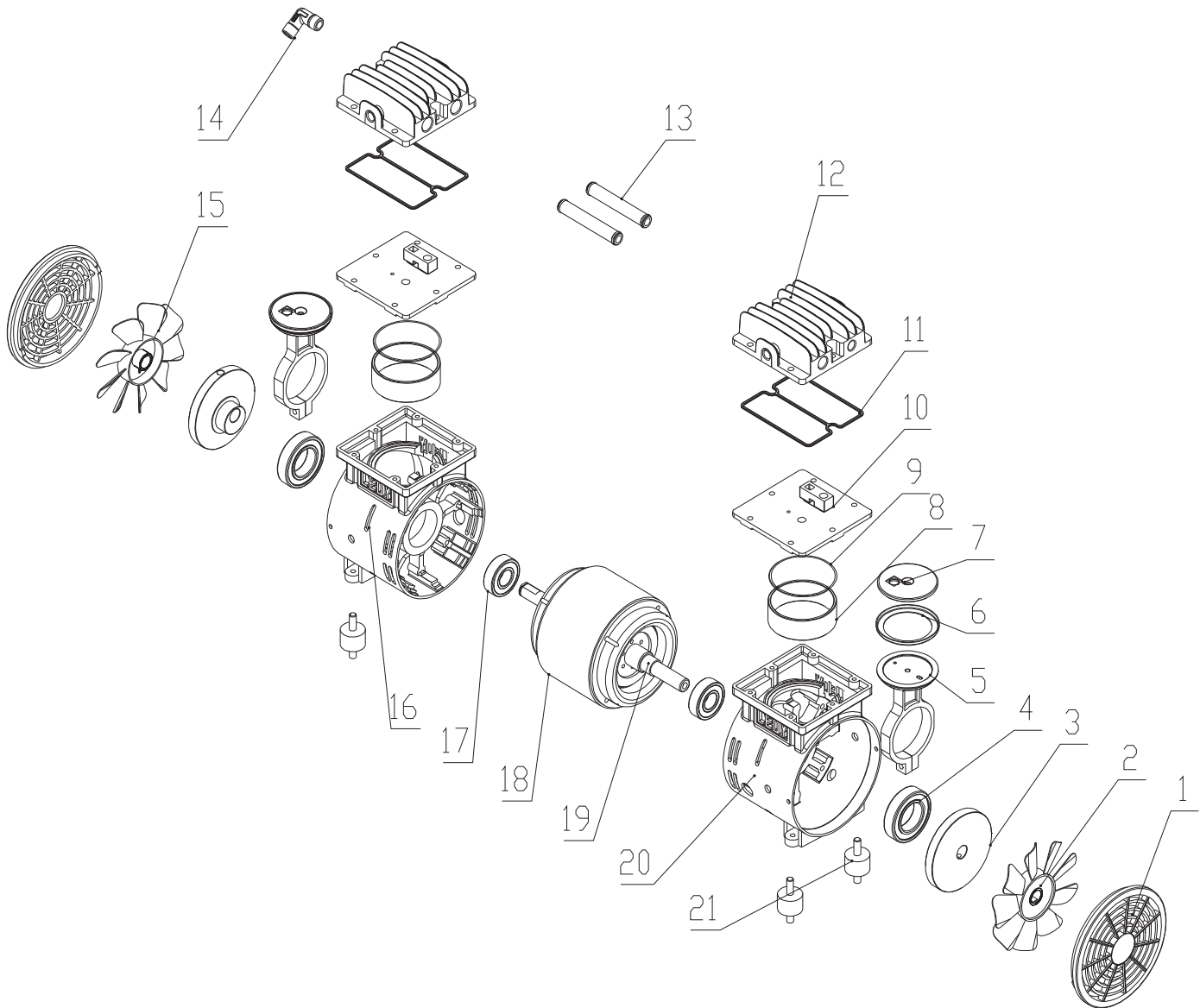

- | | | | |
|----|--------------------|----|------------------|
| 1 | Fan Cover | 12 | Cylinder Head |
| 2 | Fan A | 13 | Connect Tube |
| 3 | Crank | 14 | Eblow Connector |
| 4 | Bearing 6006-2Rs | 15 | Fan B |
| 5 | Conrod | 16 | Crankcase B |
| 6 | Piston Ring | 17 | Bearing 6203-2rs |
| 7 | Piston Cover | 18 | Stator |
| 8 | Cylinder | 19 | Rotor |
| 9 | Valve Seal | 20 | Crankcase A |
| 10 | Valve Plate | 21 | Pump Pad |
| 11 | Cylinder Head Seal | | |



WARRANTY

As part of an on-going commitment to excellence in product support, Euroquip offers a comprehensive product warranty program.

Warranty period for the RAS1500:

Commercial Use: 12 Months

Domestic Use: 12 Months

Warranty covers failure caused by manufacturing and material defects in the product, during the warranty period specified. The warranty period begins when the product is purchased by the end user. Warranty is not transferrable and is only claimable by the original purchaser.

Warranty does not cover parts that are subject to wear and tear from usage.

Warranty covers failure of a product caused by defective materials and/or manufacturing for the period given and the usage specified by Euroquip. The warranty period begins when the product is purchased by the end user. Warranty is not transferrable and is only claimable by the original purchaser.

Warranty also does not cover failure caused by the untimely replacement or service of the above wearing parts. Evidence must be provided that the product has been maintained and serviced suitably for a claim to be considered under warranty.

Failure caused by incorrect operation of the product, lack of proper care and maintenance of the product, external damage, external circumstances such as contaminated fuel or poor water supply, modifications to the product, attempted repair/ service by a party other than an Approved Service Agent, is not covered under warranty.

Warranty does not cover pre delivery service and ad-

justment, or failure that may occur as a result of lack of/ incorrect pre delivery service and adjustment.

Warranty does not cover any incidental, indirect or consequential loss, damage or expense that may result from any defect, failure or malfunction of a product.

Should any issue be found to be a combination of a warranty failure and a non-warranty issue, the repair cost component to rectify and repair the non-warranty failure is the customers' full responsibility.

The decision that an issue with a product qualifies as a warranty claim is made at the sole jurisdiction of Euroquip.

No costs incurred will be considered under warranty if repairs are carried out by a party other than a Euroquip Approved Service Agent, unless with prior consent in writing from Euroquip.

It is the responsibility of the purchaser to deliver a product under warranty to the nearest relevant service agent or product reseller. Warranty does not cover call outs, mileage and freight costs.

If a product is repaired under warranty, parts and labour required for the repair will be supplied at no charge. Warranty assessment and repair will be scheduled and executed according to the normal work flow at the service location and depending on the availability of suitable replacement parts.

This warranty policy is an additional benefit and does not affect the legal rights of any end user, reseller or service agent.



100L/MIN OIL - LESS COMPRESSOR

100L/MIN OIL - LESS COMPRESSOR



100L/MIN OIL - LESS COMPRESSOR





Congratulations on your new REMINGTON AIR product. We are proud to have you as our customer and will strive to provide you with the best service and reliability in the industry. This product is backed by our extensive warranty and service network. To locate your nearest distributor or service agency visit www.euroquip.co.nz, or email us at customerservice@euroquip.co.nz